



DEPARTMENT OF THE ARMY
THE INSTITUTE OF HERALDRY
9325 GUNSTON ROAD, ROOM S112
FORT BELVOIR, VIRGINIA 22060-5579

AAMH-IHS (840-10a)

18 October 2017

MEMORANDUM FOR Commander, Headquarters, 57th Sapper Company, ATTN: MSG Patrick DeBord, Fort Bragg, NC 28310

SUBJECT: Flash and Trim for the 57th Sapper Company

1. The request for flash and trim for the 57th Sapper Co. is approved effective 18 October 2017.
2. Enclosed for use in procurement are:
 - a. Manufacturing drawings (TIOH Dwg. No. A-4-316 and A-6-342) (Encls 1 and 2).
 - b. Color print and black and white line drawing (Encls 3 and 4).
 - c. A list of certified manufacturers and procedures for local procurement of insignia (Encls 5 and 6).
3. This authorization is in accordance with AR 670-1. A copy of this letter will become part of your permanent organizational history files.
4. Your point of contact for this action is Mr. Garrison, DSN 656-4972, COMM (703) 806-4972 or keith.a.garrison6.civ@mail.mil.

Encls

MUGNO.CHARLES.V.1020
723374

Digitally signed by MUGNO CHARLES V. 1020723374
DN: cn=US, ou=US Government, ou=DoD, ou=PKI,
ou=USA, cn=MUGNO CHARLES V. 1020723374
Date: 2017.10.18 14:07:42 -0400

CHARLES V. MUGNO
Director

CF:
The Center of Military History

REVISIONS

LTR	DESCRIPTION	DATE	APPROVED
-----	-------------	------	----------

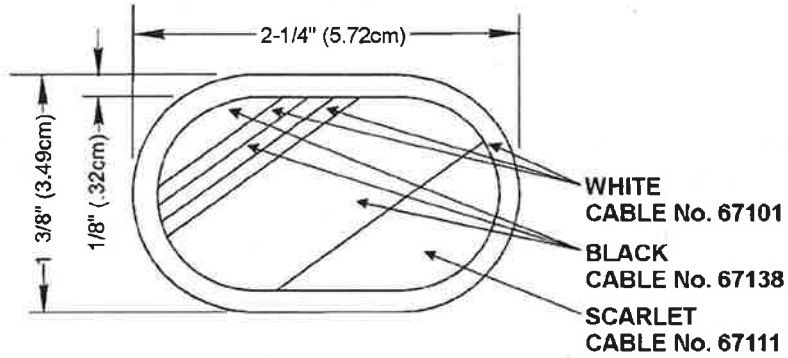

DESIGNED FOR OVEREDGE STITCHING

UNLESS OTHERWISE SPECIFIED DIMENSIONS ARE IN INCHES TOLERANCES ON FRACTIONS DECIMALS ANGLES

MATERIALS:
TO BE MANUFACTURED IN ACCORDANCE WITH MIL-DTL-14652

EXAMINED	<i>scd</i>
CHECKED	<i>CL</i>
PREPARED	CLH
APPROVED	MUGNO.CHARLES.V.10 20723374 <small>Digitally signed by CHARLES V. MUGNO, DN: cn=CHARLES V. MUGNO, o=US Army, ou=US Army, email=CHARLES.V.10@army.mil, c=US</small>
CHARLES V. MUGNO DIRECTOR	

THE INSTITUTE OF HERALDRY, DEPARTMENT OF THE ARMY
9325 GUNSTON RD, RM S-113 FORT BELVOIR, VA 22060-5579

BACKGROUND TRIMMING FOR
57TH SAPPER COMPANY

SIZE	CONTROL IDENT. NO	A-6-342
A	22571	
SCALE	FULL	DATE 28 SEPTEMBER 2017



FLASH



TRIM

*FLASH and TRIM
57TH SAPPER COMPANY*

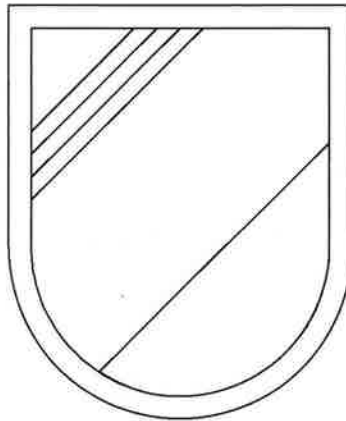

FLASH

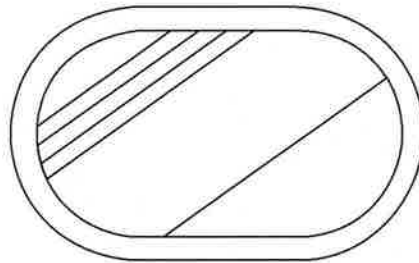

TRIM

**FLASH and TRIM
57TH SAPPER COMPANY**